

# **EXHIBIT 2**

(12) **United States Patent**  
**Evans et al.**

(10) **Patent No.:** **US 8,297,461 B2**  
 (45) **Date of Patent:** **Oct. 30, 2012**

(54) **MOISTURE RETENTION SEAL**

(75) Inventors: **Christopher T. Evans**, Long Valley, NJ (US); **Christopher Gieda**, Long Valley, NJ (US); **Kristin S. Speck**, Livermore, CA (US); **Jose M. Arevalo**, Hercules, CA (US)

(73) Assignee: **Perimeter Brand Packaging LLC**, Northborough, MA (US)

(\*) Notice: Subject to any disclaimer, the term of this patent is extended or adjusted under 35 U.S.C. 154(b) by 0 days.

(21) Appl. No.: **13/031,634**

(22) Filed: **Feb. 22, 2011**

(65) **Prior Publication Data**  
 US 2011/0220671 A1 Sep. 15, 2011

**Related U.S. Application Data**  
 (63) Continuation of application No. 12/730,528, filed on Mar. 24, 2010, now abandoned, which is a continuation of application No. 11/212,111, filed on Aug. 25, 2005, now Pat. No. 7,703,621.

(51) **Int. Cl.**  
**B65D 51/18** (2006.01)  
**B65D 51/04** (2006.01)

(52) **U.S. Cl.** ..... **220/254.3; 220/836**

(58) **Field of Classification Search** ..... 220/254.3, 220/254.1, 801, 796, 789, 794, 367.1, 810, 220/836, 361, 363, 839, 321, 666, 659, 657, 220/656, 675, 669, 655, 660, 200, 780, FOR. 203, 220/FOR. 111, FOR. 105, FOR. 100; 215/45, 215/43, 316, 324, 325, 333, 354, 902, 327, 215/344, 343, 341, 382, 317, 40, 200; *B65D 51/18*, *B65D 51/04*

See application file for complete search history.

(56) **References Cited**

U.S. PATENT DOCUMENTS

1,470,686	A *	10/1923	Carpenter	220/254.3
2,099,056	A *	11/1937	Ferngren	229/5.5
3,127,052	A *	3/1964	Mayers	220/495.11
3,298,415	A *	1/1967	Klygis	215/321
3,339,770	A *	9/1967	Bruno Weigand	215/214
3,592,349	A *	7/1971	Baugh	215/307
4,496,066	A *	1/1985	Bullock, III	215/320
4,699,285	A *	10/1987	Perne et al.	215/252
4,711,372	A *	12/1987	Gach	222/23
5,284,261	A *	2/1994	Zambuto	215/11.5
6,398,067	B1 *	6/2002	Belfance et al.	220/833
7,000,792	B2 *	2/2006	Arai	215/237
7,198,161	B2 *	4/2007	Bucholtz	215/237
2005/0045634	A1 *	3/2005	Ward et al.	220/254.3
2006/0096984	A1 *	5/2006	Bandoh et al.	220/254.5

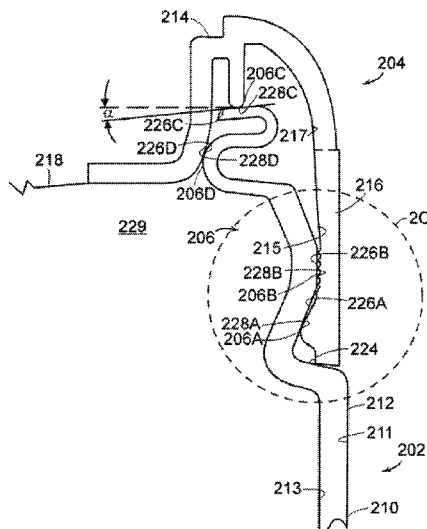
\* cited by examiner

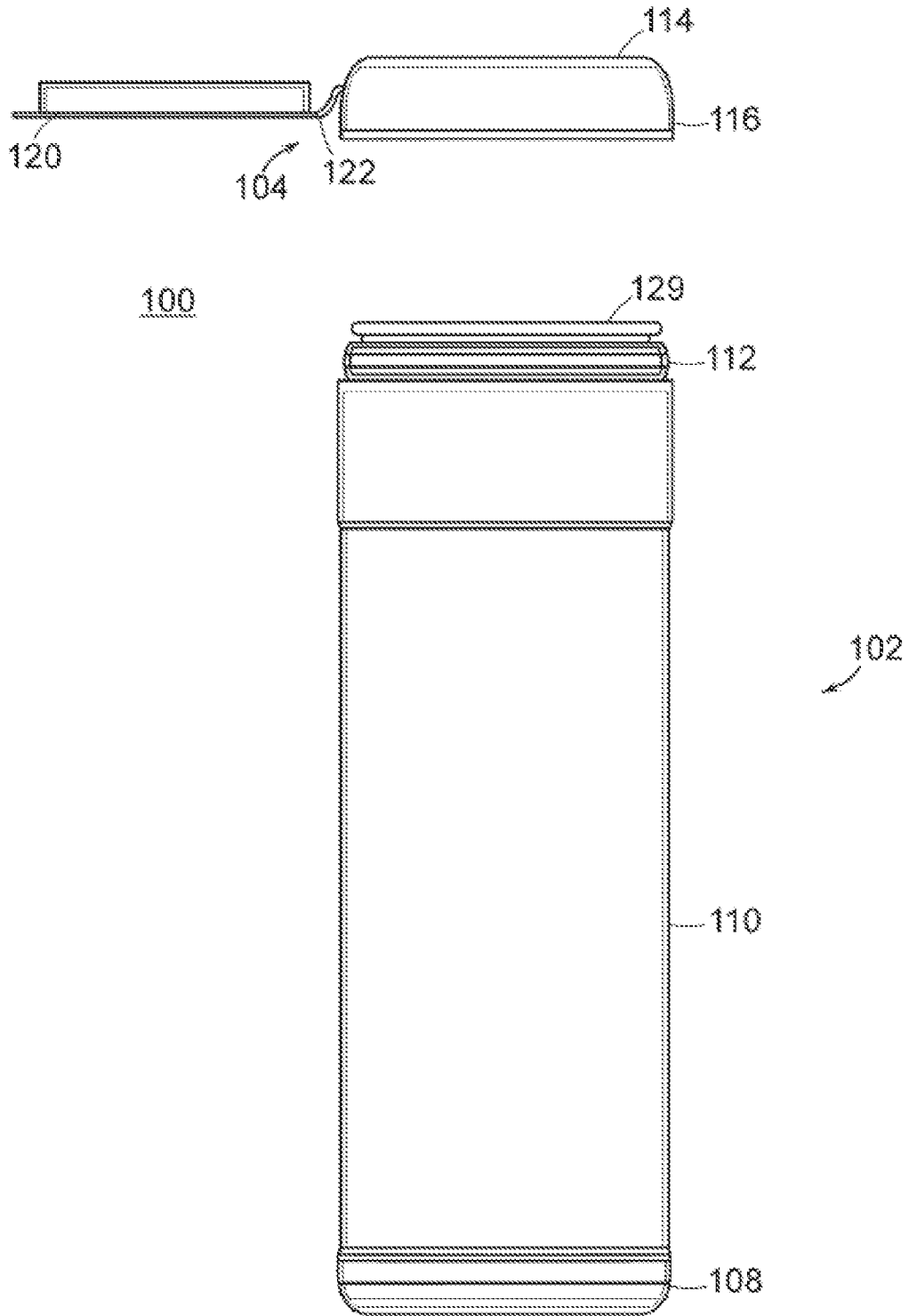
*Primary Examiner* — Mickey Yu  
*Assistant Examiner* — Robert J Hicks  
 (74) *Attorney, Agent, or Firm* — Sunstein Kann Murphy & Timbers LLP

(57) **ABSTRACT**

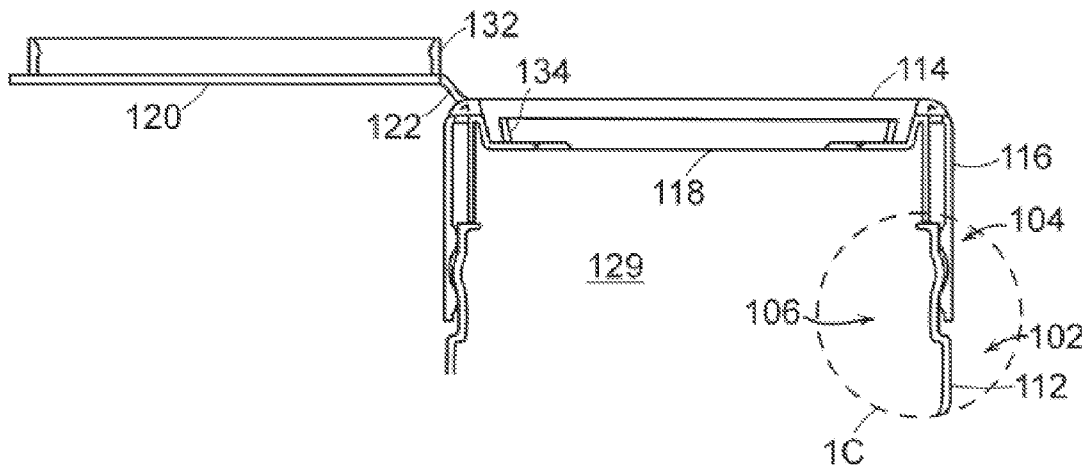
Provided is a moisture retention seal for use with a package. The moisture retention seal includes an opened-ended canister having a plurality of canister sealing surfaces. Snap-fitted with spatial interference to the canister at its opened-end, is a moisture retention closure having a plurality of closure sealing surfaces. Each canister sealing surface cooperates with a corresponding one of the closure sealing surfaces to form a plurality of partial seals. At least one of the partial seals includes a micro-bead surface comprising one or more small, inwardly directed, narrowly spaced-apart, micro-bead elements. The package that includes a moisture retention seal of the present invention employs only molded parts and does not require gaskets or secondary seals.

**17 Claims, 8 Drawing Sheets**

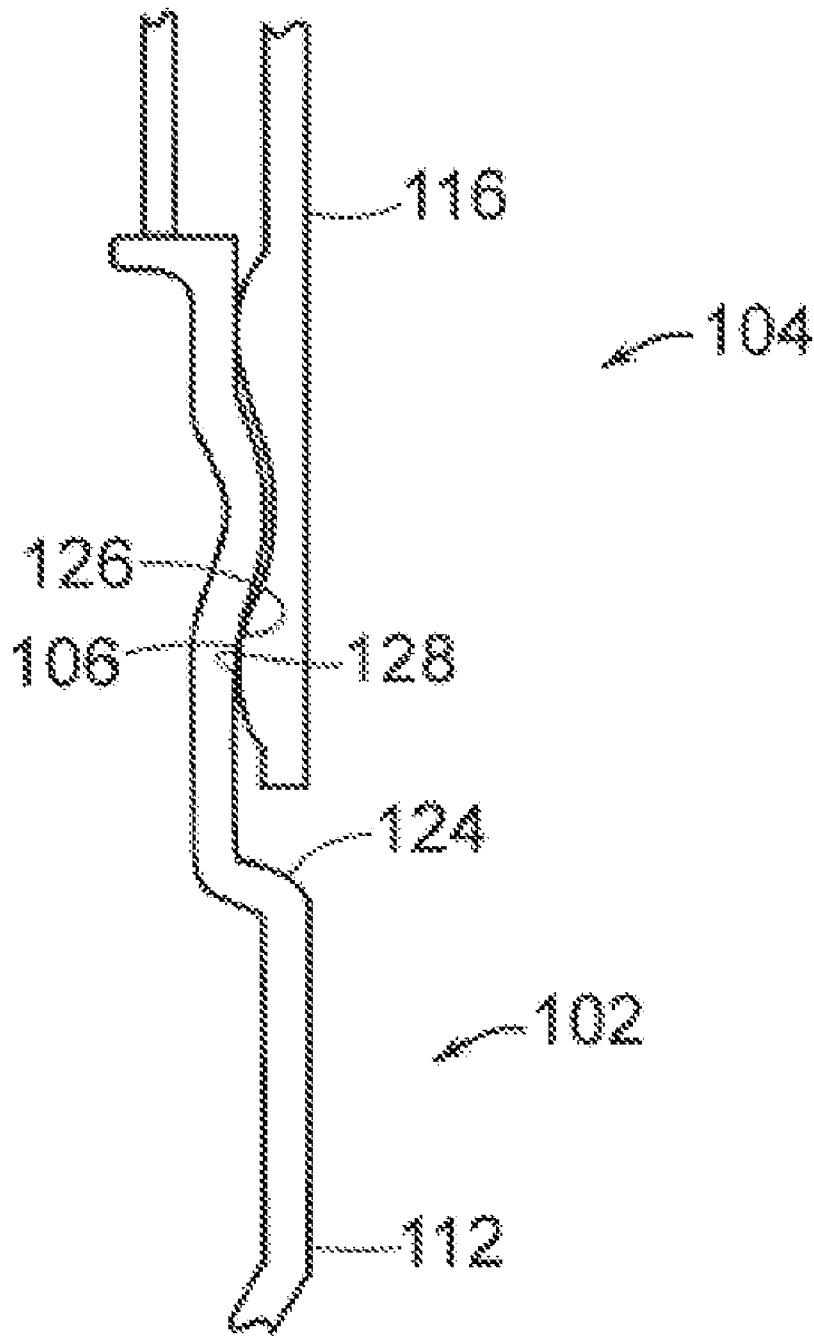




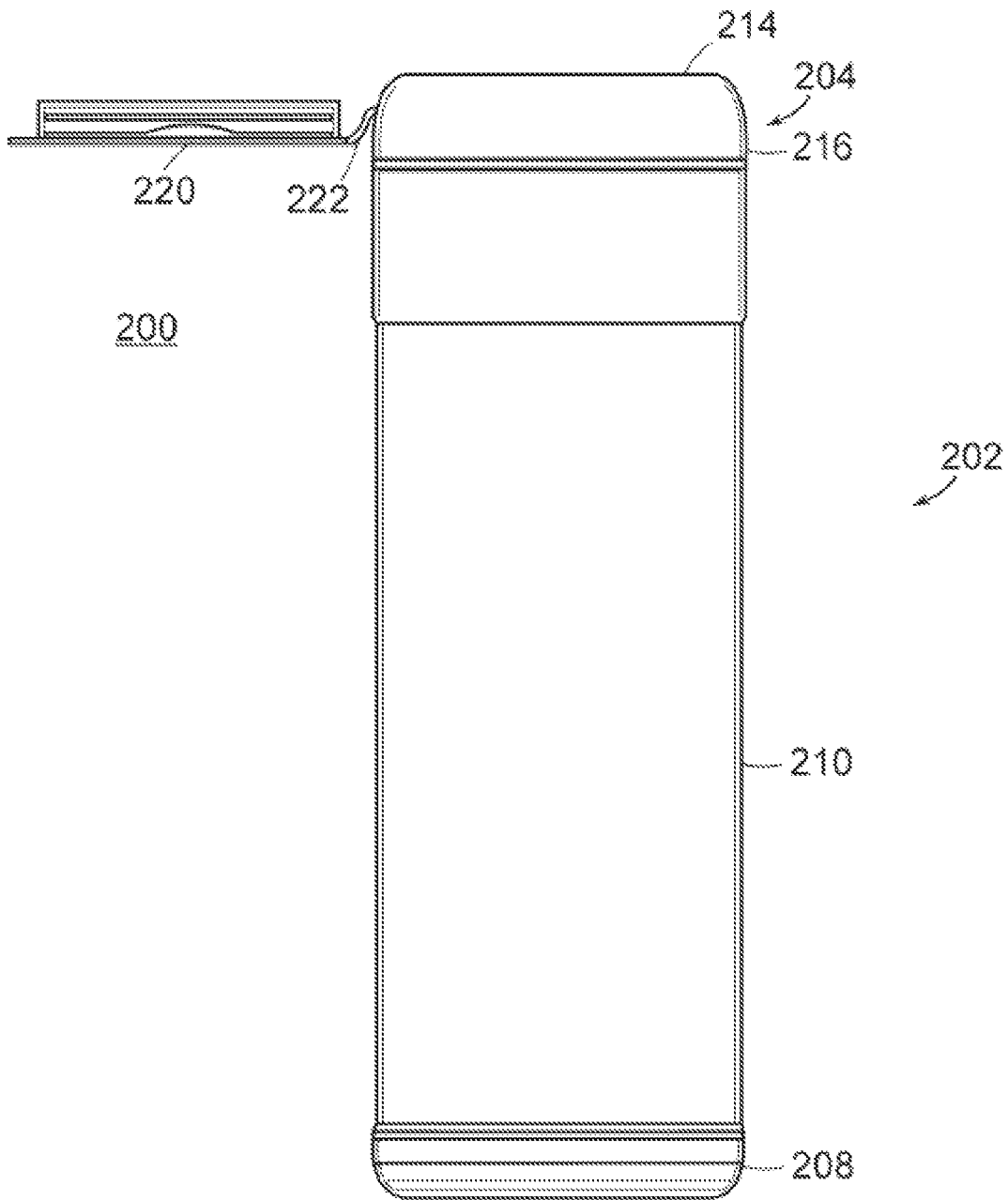
*(Prior Art)*  
**FIG. 1A**



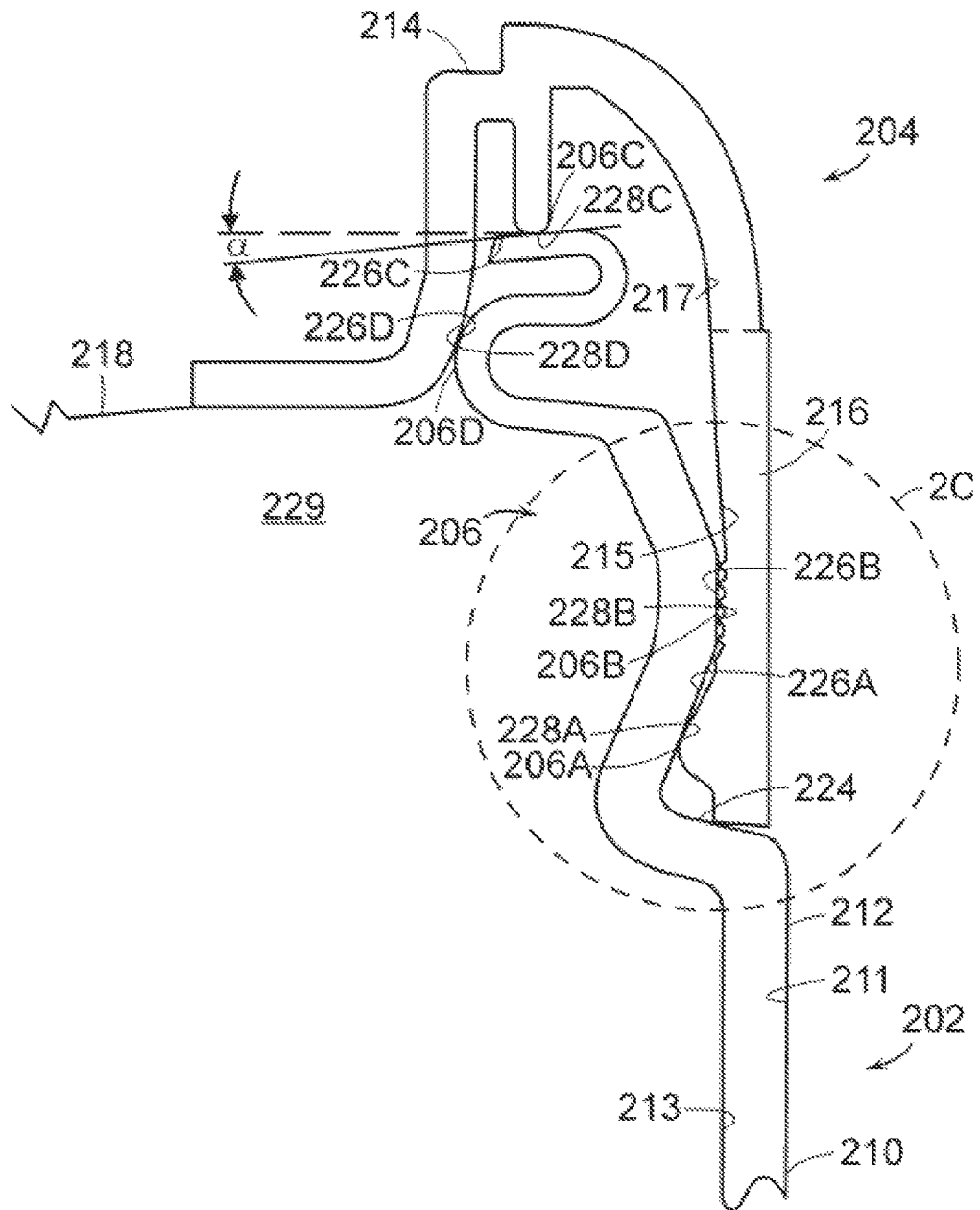
*(Prior Art)*  
**FIG. 1B**



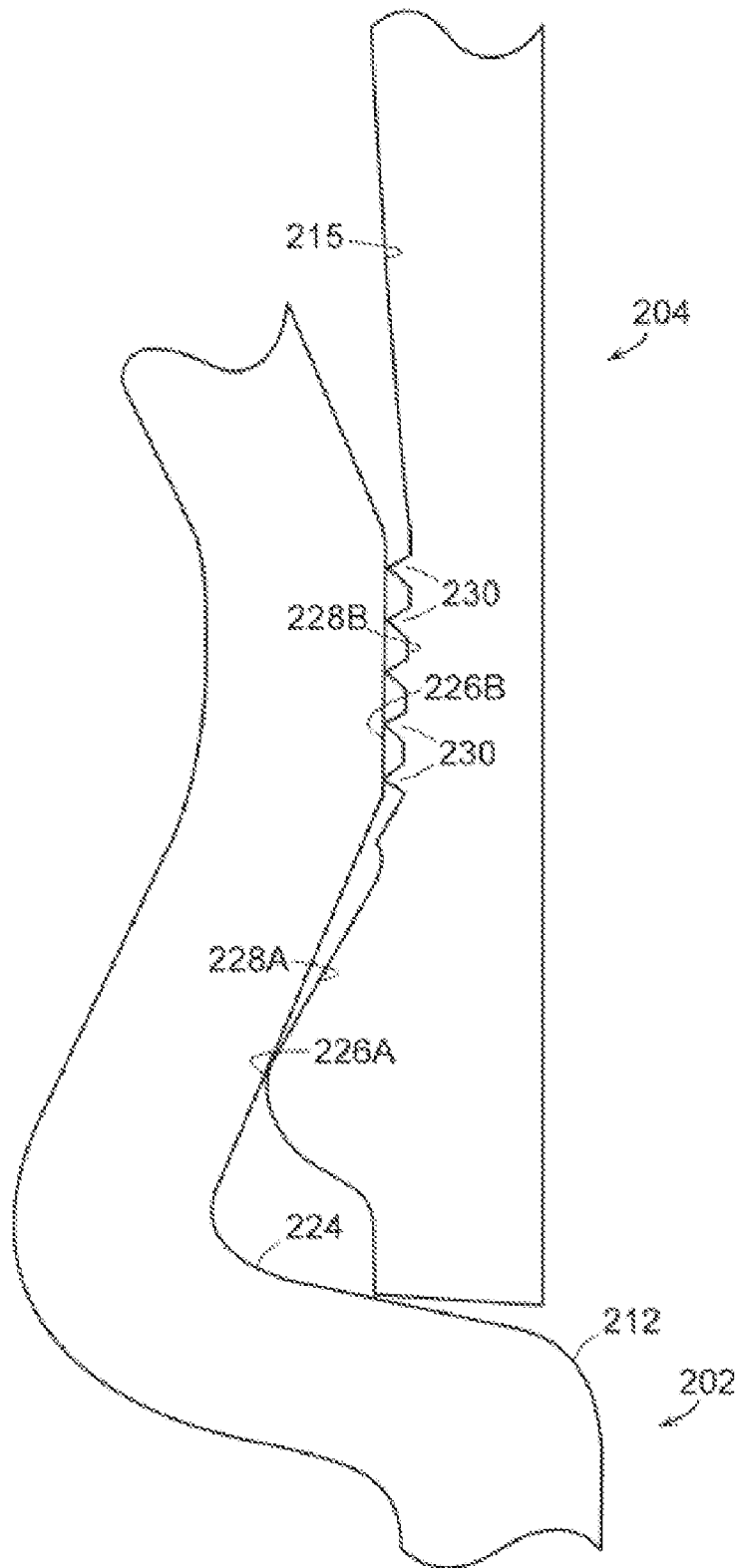
*(Prior Art)*  
**FIG. 1C**



**FIG. 2A**

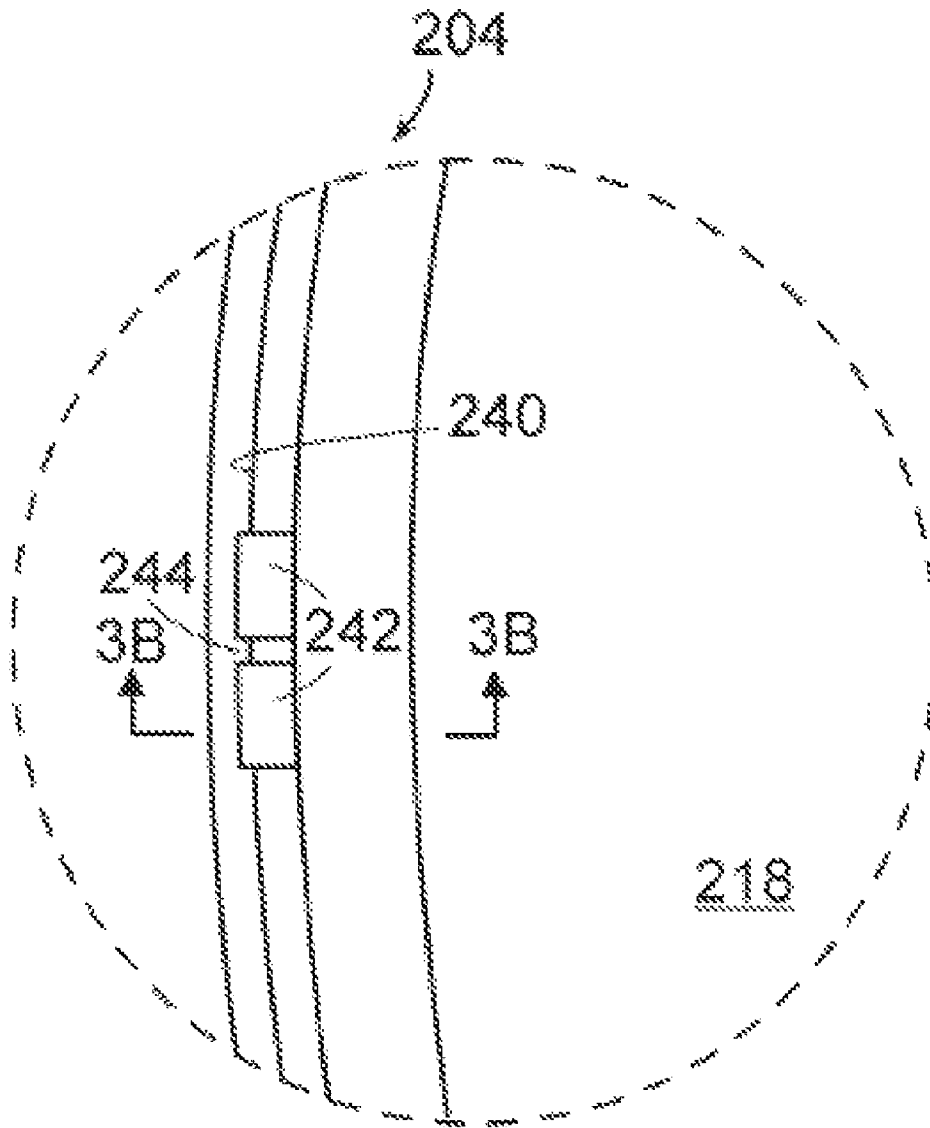


**FIG. 2B**

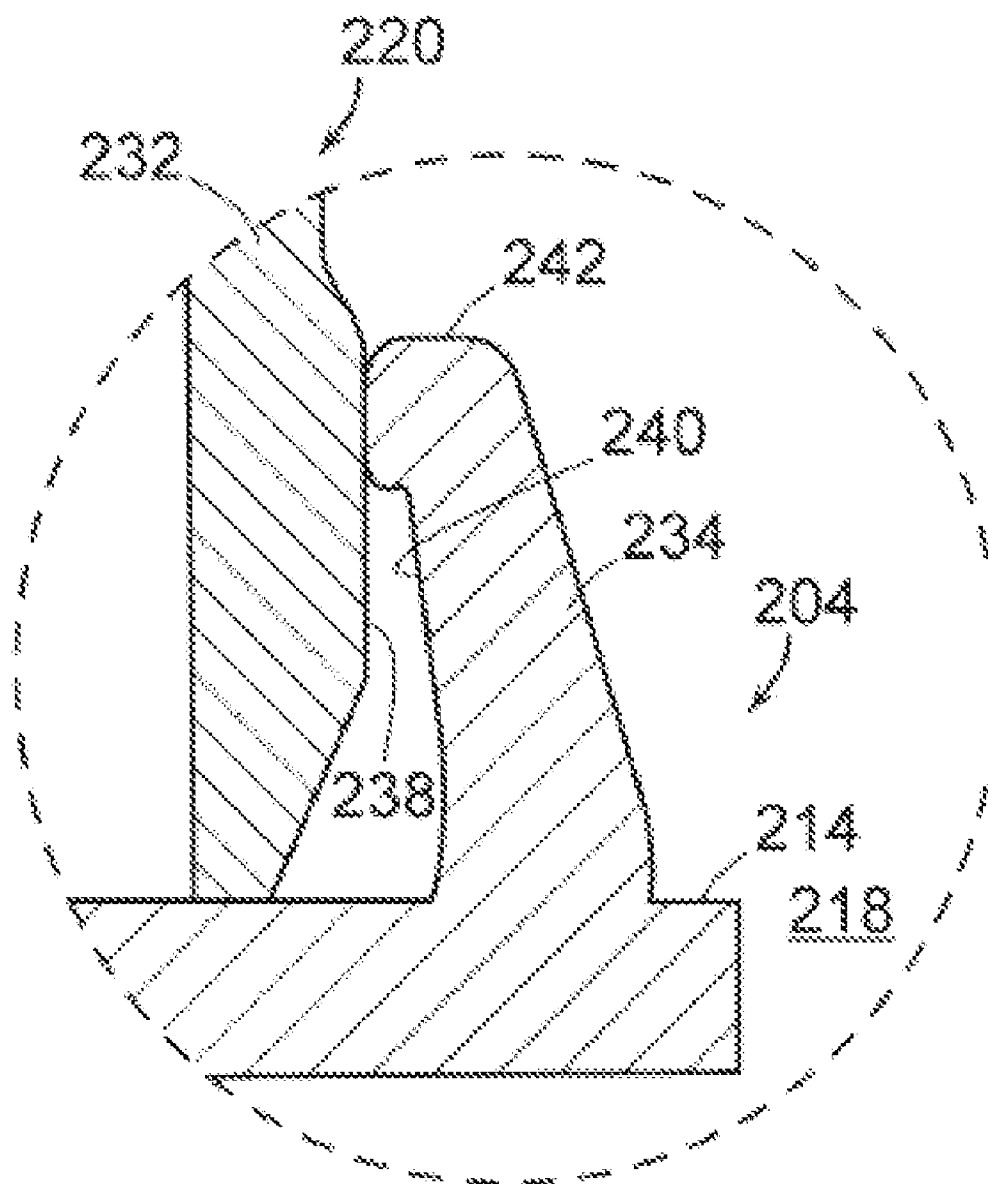


**FIG. 2C**





**FIG. 3A**



**FIG. 3B**

US 8,297,461 B2

1

**MOISTURE RETENTION SEAL****CROSS REFERENCE TO RELATED APPLICATIONS**

This application is a continuation of U.S. patent application Ser. No. 12/730,528, filed Mar. 24, 2010, titled "Moisture Retention Seal," which is a continuation of U.S. patent application Ser. No. 11/212,111, filed Aug. 25, 2005, titled "Moisture Retention Seal," the entire contents of all of which are hereby incorporated by reference herein, for all purposes.

**TECHNICAL FIELD**

The present invention relates to fluid seals and, more particularly, to a moisture retention seal for plastic packages.

**BACKGROUND ART**

FIG. 1A is an exploded side view of a prior art package 100 that included a cylindrically-shaped prior art canister 102 and a cup-shaped prior art closure 104, which was assembled telescopically over the opened-end of prior art canister 102. Prior art closure 104 has an inside diameter that is somewhat smaller than the outside diameter of prior art canister 102. Prior art canister 102 and prior art closure 104, when assembled as shown in dotted line, combined and cooperated to form a prior art seal 106 (FIG. 1B). Prior art canister 102 included a bottom 108, generally configured as a disk, and a sidewall 110, generally configured as a cylindrical surface, coupled to and extending upwardly from the peripheral edge of bottom 108. Prior art canister 102 included an opened-end portion 112 defining an opening 129 for access from the top of prior art canister 102 to material or objects contained therein. Typically, prior art canister 102 was formed integrally, by, for example, blow-molding or injection-molding of thermoplastic material.

Prior art closure 104 included a top 114, generally configured as a disk, and a skirt 116, generally configured as an annular ring, coupled to and depending downwardly from the peripheral edge of top 114. Top 114 defined an aperture 118 (FIG. 1B) therethrough for extracting material or objects contained in prior art canister 102 from its opened-end portion 112 after assembly of prior art canister 102 and prior art closure 104. Often, prior art package 100 further included an aperture lid 120 to close off aperture 118 of prior art closure 104. In one embodiment, aperture lid 120 was coupled to prior art closure 104 by a living hinge 122, by which aperture lid 120 pivoted with respect to prior art closure 104 to close off aperture 118 of prior art closure 104. Typically, prior art closure 104 was also formed integrally, by, for example, blow-molding or injection-molding of thermoplastic material. To form a seal between aperture lid 120 and closure 104, aperture lid 120 was typically snap-fitted to closure 104 in a manner well known to one of ordinary skill in the art. Aperture lid 120 included a lid sealing ring 132 near the outer peripheral edge on the bottom surface of aperture lid 120. Lid sealing ring 132 mated with a closure sealing ring 134 formed on the top surface of closure 104 when aperture lid 120 was pivoted, snap-fitted, and placed in a closed relationship with closure 104 to form a seal.

In use of prior art package 100, material or objects for containment and packaging in prior art package 100 were first placed in prior art canister 102 through opening 129 (FIG. 1B) with prior art closure 104 removed as shown in FIG. 1A. After, the material was loaded in prior art canister 102, prior art closure 104 was telescoped or fitted over and coupled to

2

prior art canister 102 by snap-fitting, thread-fitting, or other means well known to those of ordinary skill in the art. Moist or liquid materials were often packaged in prior art package 100. For example, moistened wipes were packaged within prior art package 100 for dispensing through aperture 118.

FIG. 1B is a partial cross-sectional side view of opened-end portion 112 of prior art canister 102 of FIG. 1A after assembly with prior art canister 102 showing prior art seal 106. FIG. 1C is a close-up view of the portion of FIG. 1B shown in dotted line and identified by reference number 1C showing prior art seal 106 in detail. Referring to FIGS. 1B and 1C together, the exterior surface of opened-end portion 112 of prior art canister 102 defined a sidewall groove 124, configured generally as an annular shaped indentation circumferentially about prior art canister 102. Sidewall groove 124 extended radially inwardly from and circumferentially about the exterior surface of prior art canister 102 proximate opened-end portion 112. As shown, the upper edge surface of sidewall groove 124 forms a sidewall undercut surface 126 that is beveled downwardly from its exterior to its interior indent.

The interior surface of skirt 116 of prior art closure 104 defined a skirt bead surface 128, configured generally as a peripheral flange protrusion, sometimes referred to as a bead, adjacent the bottom of skirt 116. Skirt bead surface 128 extended radially inwardly from and circumferentially about the interior surface of skirt 116 of prior art closure 104. Prior art canister 102 was assembled with prior art closure 104 by snapping skirt bead surface 128 into sidewall groove 124 whereby prior art closure 104 was retained on prior art canister 102 by means of abutting contact of skirt bead surface 128 with sidewall undercut surface 126 of sidewall groove 124.

In prior art package 100, prior art canister 102 and prior art closure 104 were further configured such that, after assembly, sidewall undercut surface 126 of sidewall groove 124 of prior art canister 102 abuttingly contacted and cooperated with corresponding skirt bead surface 128 of prior art closure 104 to form prior art seal 106. Prior art seal 106 was somewhat effective at avoiding moisture evaporation and in retaining liquid or moisture contained in prior art package 100. Prior art seal 106 slowed the loss of the liquid in the form of gaseous water vapor or other volatilized gas at the prior art seal 106 sealing interface between prior art canister 102 and prior art closure 104.

However, in the packaging industry, plastic canisters and closures often may not be accurately sized or may be out-of-round so that cooperating surfaces of the closure and canister do not properly and accurately seal. In addition, the canister and closure may be manufactured by different entities and the dimensional tolerances may vary greatly. In addition, for threaded prior art packages, to facilitate threading of the closure relative to the canister, ample thread tolerances are used, which results in axial and radial displacement sufficient to cause misalignment of the cooperating sealing surfaces. All of these variables and dimensional tolerances make it difficult to ensure a good seal in prior art packages. Poor quality seals resulted in the loss of an inordinate amount of moistening solution added to canister/closure plastic packages thereby requiring high initial moisture loading to avoid product dry-out during storage. High initial moisture loading added to over-all product cost.

In the prior art, expensive elastomeric gaskets or "O" rings were often used to provide better seals that slowed moisture loss from the package. In addition, well-known but expensive secondary seals, such as induction seals or heat seals, were

## US 8,297,461 B2

3

often used in prior art packaging to retain moisture during distribution and in-store or user storage before product use.

## SUMMARY OF EMBODIMENTS

In accordance with the principles of the present invention, provided is a moisture retention seal that avoids the limitations and expense of prior art seals. The moisture retention seal includes a first moisture retention component having a plurality of first component sealing surfaces. Assembled with the first moisture retention component is a second moisture retention component having a plurality of second component sealing surfaces. Each first component sealing surface cooperates with a corresponding one of the second component sealing surfaces to form a plurality of partial seals. At least one of the partial seals comprises one or more small projections, sometimes referred to as micro-bead elements. In one embodiment, first moisture retention component, second moisture retention component, or both are formed from molded thermoplastic material.

When it is said herein that a first surface cooperates with second surface to form a seal, it is meant that the first and second surfaces abuttingly contact each other and deform sufficiently due to spatial interference to form a fluid seal useful in preventing moisture transfer across the seal. When it is said herein that a first sealing surface corresponds to a second sealing surface, it is meant that the first sealing surface and second sealing surface are intended to cooperate to form a moisture retention seal.

Embodiments of a moisture retention seal for use with a package include an opened-ended canister having a plurality of canister sealing surfaces. Snap-fitted to the canister at its opened-end is a moisture retention closure having a plurality of closure sealing surfaces. Each canister sealing surface cooperates with a corresponding one of the closure sealing surfaces to form a plurality of partial seals. The closure may be configured to be slightly smaller in diameter than the canister, thereby forming an interference fit between the closure and the canister. The interference may provide a sealing engagement between the closure and the canister at the points of interference along the plurality of cooperating partial seals. At least one of the partial seals includes a micro-bead surface comprising one or more small, inwardly directed, narrowly spaced-apart, micro-bead elements. In one embodiment, a package that includes a moisture retention seal employs only molded parts and does not require expensive gaskets or secondary seals. Accordingly, the moisture retention seal of the present invention avoids the limitations and expense of prior art seals.

## BRIEF DESCRIPTION OF THE DRAWINGS

The foregoing aspects and others will be readily appreciated by the skilled artisan from the following description of illustrative embodiments when read in conjunction with the accompanying drawings, wherein:

FIG. 1A is an exploded side view of a prior art package that included a cylindrically-shaped prior art canister and a cup-shaped prior art closure;

FIG. 1B is a partial cross-sectional side view of an opened-end portion of the prior art canister of FIG. 1A after assembly with the prior art closure and showing a prior art seal;

FIG. 1C is a close-up view of the portion of FIG. 1B shown in dotted line and identified by reference number 1C showing the prior art seal in detail;

FIG. 2A is a side view of an assembled moisture retention package that includes a cylindrical moisture retention canis-

4

ter and a cup-shaped moisture retention closure coupled to and cooperating with the moisture retention canister to provide an embodiment of a moisture retention seal in accordance with the principles of the present invention;

FIG. 2B is a cross-sectional close-up side view of an opened-end portion of the moisture retention canister that shows a plurality of partial seals after assembly of the moisture retention closure and moisture retention canister;

FIG. 2C is a further close-up view of the portion of FIG. 2B shown in dotted line and identified by reference number 2C' showing a skirt micro-bead surface in detail;

FIG. 3A is a partial, close-up, top view of the moisture retention closure of FIG. 2A showing moisture retention closure ring stand-offs that provide venting to the moisture retention package of FIG. 2A; and

FIG. 3B is a close-up, partial, cross-sectional side view of moisture retention closure 204 as in FIG. 2B along line 3B-3B of FIG. 3A also showing an aperture lid 220 in a closed relationship with the moisture retention closure.

Reference will now be made to the drawings wherein like numerals refer to like parts throughout. As used herein, positional terms, such as "bottom" and "top" and the like, and directional terms, such as "up", "down" and the like, are employed for ease of description in conjunction with the drawings. Further, the terms "interior", "inwardly" and the like, refer to positions and directions toward the geometric center of embodiments of the present invention and designated parts thereof. The terms "exterior", "outwardly", and the like, refer to positions and directions away from the geometric center. None of these terms is meant to indicate that the described components must have a specific orientation except when specifically set forth.

## DETAILED DESCRIPTION OF SPECIFIC EMBODIMENTS

FIG. 2A is a side view of an assembled moisture retention package 200 that includes a cylindrical moisture retention canister 202 and a cup-shaped moisture retention closure 204 coupled to and cooperating with moisture retention canister 202 to provide an embodiment of a moisture retention seal 206 (FIG. 2B) in accordance with the principles of the present invention. In one embodiment, moisture retention canister 202 includes a bottom 208, generally configured as a disk, and a sidewall 210, generally configured as a cylindrical surface, coupled to and extending upwardly from the peripheral edge of bottom 208. Moisture retention canister 202 includes an opened-end portion 212 (FIG. 2B) defining an opening 229 (FIG. 2B) for access from the top of moisture retention canister 202 to material or objects contained therein. In one embodiment moisture retention canister 202 is integrally formed and comprises blow-molded or injection-molded thermoplastic material.

In one embodiment, moisture retention closure 204 includes a top 214, generally configured as a disk, and a skirt 216, generally configured as an annular ring or skirt, coupled to and depending downwardly from top 214 at the peripheral edge of top 214. Top 214 defines an aperture 218 (FIG. 2B) therethrough for extracting material or objects contained in moisture retention canister 202 from opened-end portion 212 (FIG. 2B). In one embodiment, moisture retention closure 204 is integrally formed by blow-molding or injection-molding and comprises thermoplastic material.

In one embodiment, moisture retention package 200 further includes an aperture lid 220 to close off aperture 218. Aperture lid 220 may be coupled to moisture retention closure 204 by a living hinge 222, by which aperture lid 220

## US 8,297,461 B2

5

pivots with respect to moisture retention closure **204** to close off aperture **218** (FIG. 2B) of moisture retention closure **204**.

FIG. 2B is a cross-sectional close-up side view of opened-end portion **212** of moisture retention canister **202** that shows various seals **206A-206D** after assembly of moisture retention closure **204** and moisture retention canister **202**. In illustrative embodiments, the plurality of seals are partial seals that together can form a complete seal that adequately seals for anticipated uses. For example, each partial seal may have a small unsealed area. The combination of these small unsealed areas, however, may present a relatively tortuous path for vapor to escape, thus providing an effective seal for certain applications. In other embodiments, however, at least one of the seals is a full seal. In such case, the other full or partial seals simply are redundant. In either case, it is anticipated that redundant seals can help ensure that at least one is a full seal, or at least the combination of partial seals provides the requisite sealing capabilities. Such use of redundant seals should increase the likelihood that wide error factors and tolerances of some technologies (e.g., blow molding technology) does not eliminate sealing requirements. Unless the context requires otherwise or the seal is explicitly specified as a partial or full seal, seals discussed herein thus may be either partial or full seals.

Referring to FIG. 2B and directing attention to moisture retention canister **202**, sidewall **210** comprises a plurality of sealing surfaces **226A-226D**. As shown in FIG. 2B, sidewall **210** has a first, i.e., an exterior, sidewall surface **211** and a second, i.e., an interior, sidewall surface **213** opposite exterior sidewall surface **211**. Exterior sidewall surface **211** of moisture retention canister **202** defines sidewall sealing surfaces that include a sidewall undercut surface **226A**, a sidewall upright surface **226B**, and a sidewall lip surface **226C**. In one embodiment, sidewall undercut surface **226A**, sidewall upright surface **226B**, and sidewall lip surface **226C**, circumferentially extend about exterior sidewall surface **211** of moisture retention canister **202**.

With reference to sidewall undercut surface **226A**, exterior sidewall surface **211** has sidewall groove **224**, configured generally as an annular shaped indentation about moisture retention canister **202** proximate opened-end portion **212**. Sidewall groove **224** extends radially inward from and circumferentially about exterior sidewall surface **211** of moisture retention canister **202**. As shown, the upper edge surface of sidewall groove **224** forms sidewall undercut surface **226A**. In one embodiment, sidewall undercut surface **226A** slants downwardly from exterior sidewall surface **211** to its interior indent.

With reference to sidewall upright surface **226B**, in one embodiment, sidewall upright surface **226B** is above sidewall undercut surface **226A** and is configured generally as an annular ring with a substantially flat-face directed outwardly.

With reference to sidewall lip surface **226C**, in one embodiment, sidewall lip surface **226C** is the top generally horizontal annular surface of exterior sidewall surface **211** forming a flat-faced upper lip or rim of moisture retention canister **202**. As described more fully below, sidewall lip surface **226C** deflects and pivots downwardly by a deflection angle  $\alpha$  from its unassembled relaxed horizontal position whenever moisture retention closure **204** is fully assembled and engaged with moisture retention canister **202**.

In one embodiment, interior sidewall surface **213** of moisture retention canister **202** defines a sidewall bead surface **226D** circumferentially extending about interior sidewall surface **213**. Sidewall bead surface **226D** is configured generally as a peripheral flange protrusion, sometimes, as described above, referred to as a bead, adjacent and below sidewall lip

6

surface **226C**. Sidewall bead surface **226D** extends radially inwardly from and circumferentially about interior sidewall surface **213** of moisture retention canister **202**.

Referring still to FIG. 2B but directing attention to moisture retention closure **204**, skirt **216** and top **214** of moisture retention closure **204** comprise a plurality of sealing surfaces **228A-228D**. In one embodiment, skirt **216** of moisture retention closure **204** has a first, i.e., an interior, skirt surface **215**. Skirt interior surface **215** of moisture retention closure **204** defines sidewall sealing surfaces that include a skirt bead surface **228A** and a skirt micro-bead surface **228B**.

With reference to skirt bead surface **228A**, in one embodiment, skirt bead surface **228A** is configured as a bead, as described above, adjacent the bottom of skirt **216**. Skirt bead surface **228A** extends radially inwardly from and circumferentially about skirt interior surface **215** of moisture retention closure **204**. When moisture retention package **200** is assembled as described, skirt bead surface **228A** of closure **204** cooperates with sidewall undercut surface **226A** of canister **202** to form a first partial seal **206A**.

With reference to skirt micro-bead surface **228B** FIG. 2C is a further close-up view of the portion of FIG. 2B shown in dotted line and identified by reference number **2C** showing skirt micro-bead surface **228B** in detail. Referring now to FIGS. 2B and 2C together, in one embodiment, skirt micro-bead surface **228B** is configured as one or more, small, narrowly spaced-apart beads, sometimes referred to as micro-bead elements **230**, best seen in FIG. 2C. In illustrative embodiments, the micro-bead elements **230** each have bases that are spaced approximately one to four base thicknesses apart.

In one embodiment, each micro-bead element **230** of micro-bead surface **228B** protrudes from skirt interior surface **215** toward the interior of moisture retention closure **204** by about 0.013 inches. Adjacent micro-bead elements **230** are spaced-apart by about 0.030 inches. The micro-bead elements **230** making up micro-bead surface **228B** cooperate with sidewall upright surface **226B** to form a second partial seal **206B**. Micro-bead surface **228B** is particularly effective in retaining moisture within moisture retention package **200** when moisture retention canister **202** and moisture retention closure **204** are assembled. Each of the micro-bead elements **230** abuttingly contacts sidewall upright surface **226B**, which together form a tight seal.

In one embodiment, moisture retention closure **204** has an inside diameter at skirt bead surface **228A** that is somewhat smaller than moisture retention canister **202** outside diameter at corresponding sidewall undercut surface **226A**. Further, moisture retention closure **204** has an inside diameter at skirt micro-bead surface **228B** that is somewhat smaller than moisture retention canister **202** outside diameter at corresponding sidewall upright surface **226B**. Accordingly, as is well known to those of ordinary skill in the art, moisture retention closure **204** snap-fits to moisture retention canister **202** when assembled as shown in FIG. 2A. When it is said herein that the diameter of a surface of a component is somewhat smaller than the diameter of a surface of another component, it is meant that the diameters differ in length by an amount that allows cooperation between the components to form spatial interference therebetween. In one embodiment the inside diameter at skirt bead surface **228A** is smaller than the outside diameter of sidewall undercut surface **226A** by about 0.014 inches. The inside diameter of skirt micro-bead surface **228B** is smaller than the outside diameter of sidewall upright surface **226B** by about 0.029 inches. The inside diameters must not be so much smaller than the outside diameters such that

moisture retention closure **204** will not conveniently snap-fit on moisture retention canister **202**.

Referring again to FIG. 2B, further, top **214** of moisture retention closure **204** has a first, i.e., an interior, top surface **217**. Top interior surface **217** of moisture retention closure **204** defines sealing surfaces that include a top protrusion surface **228C** and a top undercut surface **228D**. In one embodiment, top protrusion surface **228C** and top undercut surface **228D** circumferentially extend about interior top surface **217** of moisture retention closure **204**.

With reference to top protrusion surface **228C**, in one embodiment, top protrusion surface **228C** is configured as a tang or projection coupled to and protruding downwardly from top interior surface **217**. When moisture retention package **200** is assembled as described, top protrusion surface **228C** of closure **204** cooperates with sidewall lip surface **226C** of canister **202** to form a third partial seal **206C**. As noted above, sidewall lip surface **226C** deflects somewhat downwardly from its unassembled relaxed position, by deflection angle  $\alpha$ , whenever moisture retention closure **204** is fully assembled and engaged with moisture retention canister **202**. The downward deflection of sidewall lip surface **226C** generates, at top protrusion surface **228C**, an upwardly biasing force on closure **204**, as sidewall lip surface **226C** tends to elastically return to its relaxed position. The upwardly biasing force on closure **204** at top protrusion surface **228C** causes sidewall lip surface **226C** to more forcefully engage sidewall lip surface **226C** in abutting contact, thereby forming a more effective third partial seal **206C**. Further, the upwardly biasing force on closure **204** causes skirt bead surface **228A** to more forcefully engage undercut surface **226A** in abutting contact, thereby forming a more effective first partial seal **206A**. In one embodiment, deflection angle  $\alpha$  is about  $5^\circ$ .

With reference to top undercut surface **228D**, in one embodiment, top undercut surface **228D** is configured as a bead extending circumferentially about top interior surface **217**. When moisture retention canister **202** and moisture retention closure **204** are assembled, top undercut surface **228D** cooperates with sidewall bead surface **226D** to form a fourth partial seal **206D**.

As noted above, in one embodiment, moisture retention closure **204** has an inside diameter at skirt bead surface **228A** that is somewhat smaller than moisture retention canister **202** outside diameter at corresponding sidewall undercut surface **226A**. Further, moisture retention closure **204** has an inside diameter at skirt micro-bead surface **228B** that is somewhat smaller than moisture retention canister **202** outside diameter at corresponding sidewall upright surface **226B**. Thus, when assembled as shown in FIG. 2A, moisture retention closure **204** and moisture retention canister **202** spatially interfere at first partial seal **206A** and second partial seal **206B**. Moisture retention closure **204** may thus “snap-fit” when assembled to moisture retention canister **202**.

To accommodate the spatial interferences at first partial seal **206A** and second partial seal **206B**, opened-end portion **212** of moisture retention canister **202** tends to lengthen. The lengthening of opened-end portion **212** in turn creates a more effective third partial seal **206C**, since sidewall lip surface **226C** of canister **202** is, in turn, more forcefully biased against and more effectively seated with top protrusion surface **228C** of closure **204**. To accommodate this more forceful biasing at third partial seal **206C**, deflection angle  $\alpha$  of canister **202** tends to increase and sidewall bead surface **226D** tends to deflect inwardly toward top undercut surface **228D** of moisture retention closure **204** thereby, in turn, creating a more effective fourth partial seal **206D**.

Thus, it can be seen that the interference created by selecting moisture retention closure **204** with inside diameters at skirt bead surface **228A** and skirt micro-bead surface **228B** that are somewhat smaller, respectively, than the outside diameters of sidewall undercut surface **226A** and sidewall upright surface **226B** of moisture retention canister **202**, produces more effective seals at all the partial seals **206A-206D** of moisture retention package **200**. A more effective overall “system” of cooperating partial seals is created by selection of the diameters of moisture retention canister **202** and moisture retention closure **204**. The various elements of the seal “system” flex and deflect as described to accommodate induced forces thereby creating a more effective overall sealing system.

To determine the effectiveness of moisture retention seal **206**, comprising partial seals **206A-206D**, moisture retention package **200** was tested and compared to prior art seal **106** (FIG. 1C) of prior art package **100** (FIG. 1A) for weight percent moisture loss over time.

Table 1 summarizes the weight percent moisture loss over time for moistened automotive interior protectant wipes stored in moisture retention package **200** as compared to identical wipes stored in prior art package **100** (FIG. 1A). As shown, wipes were stored at a constant ambient temperature of  $70^\circ\text{F}$ . and at constant elevated temperatures to accelerate results. The solution moistening the protectant wipes comprised 23.0 weight percent solids 77.0 weight percent aqueous volatiles.

As shown in Table 1 cumulative weight percent (wt %) moisture loss for moistened protectant wipes stored in moisture retention package **200** at  $120^\circ\text{F}$ . amounted to 6.74 wt % loss over a twelve-week period. By comparison, protectant wipes stored in prior art package **100** (FIG. 1A) lost 37.87 wt %. Moisture loss for moisture retention package **200** amounted to only 17.8% of the moisture loss for prior art package **100** (FIG. 1A) under these conditions ( $120^\circ\text{F}$ ., 12 weeks).

Table 2 summarizes the weight percent moisture loss over time for moistened general purpose orange scented cleaning wipes stored in moisture retention package **200** as compared to identical wipes stored in prior art package **100** (FIG. 1A). The solution moistening the orange scented cleaning wipes comprised 1.2 weight percent solids and 98.8 weight percent aqueous volatiles.

As shown in Table 2 cumulative weight percent moisture loss for moistened orange scented cleaning wipes stored in moisture retention package **200** at  $120^\circ\text{F}$ . amounted to 8.40 wt % loss over a twelve-week period. By comparison, orange scented cleaning wipes stored in prior art package **100** (FIG. 1A) lost 39.41 wt %. Moisture loss for moisture retention package **200** amounted to only 21.3% of the moisture loss for prior art package **100** (FIG. 1A) under these conditions ( $120^\circ\text{F}$ ., 12 weeks). When stored at a temperature of  $140^\circ\text{F}$ ., cumulative weight percent moisture loss amounted to 13.72 wt % and 69.70 wt % for moisture retention package **200** and prior art package **100** (FIG. 1A), respectively. Moisture loss for moisture retention package **200** amounted to only 19.7% of the moisture loss for prior art package **100** (FIG. 1A) under these conditions ( $140^\circ\text{F}$ ., 12 weeks).

Table 3 summarizes the weight percent moisture loss over time for moistened leather cleaning wipes stored in moisture retention package **200** as compared to identical wipes stored in prior art package **100** (FIG. 1A). The solution moistening the leather cleaning wipes comprised 10.7 weight percent solids and 89.3 weight percent aqueous volatiles.

As shown in Table 3 cumulative weight percent moisture loss for moistened leather cleaning wipes stored in moisture

US 8,297,461 B2

9

retention package **200** at 100° F. amounted to 4.56 wt % loss over a twelve-week period. By comparison, leather cleaning wipes stored in prior art package **100** (FIG. 1A) lost 20.21 wt %. Moisture loss for moisture retention package **200** amounted to only 22.7% of the moisture loss for prior art package **100** (FIG. 1A) under these conditions (100° F., 12 weeks). When stored at a temperature of 120 F, cumulative weight percent moisture loss amounted to 11.08 wt % and 44.96 wt % for moisture retention package **200** and prior art package **100** (FIG. 1A), respectively. Moisture loss for moisture retention package **200** amounted to only 24.6% of the moisture loss for prior art package **100** (FIG. 1A) under these conditions (120° F., 12 weeks). When stored at a temperature of 140° F., cumulative weight percent moisture loss amounted to 11.87 wt % and 52.44 wt % for moisture retention package **200** and prior art package **100** (FIG. 1A), respectively. Moisture loss for moisture retention package **200** amounted to only 22.6% of the moisture loss for prior art package **100** (FIG. 1A) under these conditions (140° F., 12 weeks).

Moisture Weight Loss Summary

TABLE 1

Protectant Wipes					
	Week 1	Week 2	Week 4	Week 8	Week 12
Moisture Retention Seal Package					
70° F.					
Weight % Lost	0.015	0.17	0.28	0.52	0.78
Standard Dev.	0.02	0.02	0.03	0.04	0.05
100° F.					
Weight % Lost	0.029	0.50	1.03	2.03	3.06
Standard Dev.	0.04	0.08	0.20	0.38	0.59
120° F.					
Weight % Lost	0.69	1.16	2.31	4.50	6.74
Standard Dev.	0.017	0.18	0.29	0.61	1.04
140° F.					
Weight % Lost	0.98	1.87	3.68	7.30	10.74
Standard Dev.	0.07	0.32	0.74	1.29	2.04
Controls (Prior Art Package)					
120° F.					
Weight % Lost	3.50	6.20	12.59	25.11	37.87
Standard Dev.	0.81	1.37	2.72	5.41	8.30

TABLE 2

Orange Scented Cleaning Wipes					
	Week 1	Week 2	Week 4	Week 8	Week 12
Moisture Retention Seal Package					
70° F.					
Weight % Lost	0.16	0.19	0.36	0.75	1.18
Standard Dev.	0.07	0.07	0.08	0.09	0.11
100° F.					
Weight % Lost	0.43	0.77	1.51	2.95	4.42
Standard Dev.	0.07	0.08	0.11	0.16	0.31
120° F.					
Weight % Lost	0.85	1.53	2.34	5.43	8.40
Standard Dev.	0.06	1.16	1.19	0.53	0.82

10

TABLE 2-continued

Orange Scented Cleaning Wipes					
	Week 1	Week 2	Week 4	Week 8	Week 12
140° F.					
Weight % Lost	1.22	2.35	5.17	9.52	13.72
Standard Dev.	0.10	0.22	0.40	0.78	1.14
Controls (Prior Art Package)					
120° F.					
Weight % Lost	3.83	7.16	13.43	25.88	39.41
Standard Dev.	2.85	4.41	6.68	11.44	16.11
140° F.					
Weight % Lost	4.83	10.58	23.92	47.30	69.70
Standard Dev.	3.23	4.03	-5.54	8.75	10.86

TABLE 3

Leather Cleaning Wipes					
	Week 1	Week 2	Week 4	Week 8	Week 12
Moisture Retention Seal Package					
70° F.					
Weight % Lost	0.19	0.22	0.43	0.88	1.35
Standard Dev.	0.03	0.03	0.05	0.11	0.19
100° F.					
Weight % Lost	0.34	0.68	1.43	2.98	4.56
Standard Dev.	0.05	0.05	0.15	0.42	0.69
120° F.					
Weight % Lost	1.13	1.86	3.82	7.59	11.08
Standard Dev.	0.15	0.11	0.38	1.19	1.72
140° F.					
Weight % Lost	1.25	2.26	4.56	8.13	11.87
Standard Dev.	0.07	0.12	0.34	0.79	1.10
Controls (Prior Art Package)					
100° F.					
Weight % Lost	2.85	4.21	7.21	13.52	20.21
Standard Dev.	1.29	1.57	2.04	3.09	4.26
120° F.					
Weight % Lost	3.73	6.81	16.52	31.45	44.96
Standard Dev.	4.03	5.13	10.31	14.96	18.81
140° F.					
Weight % Lost	5.45	10.17	20.84	37.58	52.44
Standard Dev.	3.03	4.51	8.10	14.48	18.58

As described and shown in the above tables, moisture retention package **200** employing moisture retention seal **206** in accordance with the principles of the present invention is an effective means to prevent moisture loss from plastic moisture retention package **200**. The moisture retention effects of partial seals **206A-206D** combine to form moisture retention seal **206** that is significantly more effective than prior art seal **106** (FIG. 1C). Moisture loss at elevated storage temperatures from moisture retention package **200** is only about 17 to 25%, on average, of the loss from a prior art package **100** (FIG. 1A). Said another way, moisture retention package **200** has a “moisture loss factor” of about 17% to 25%, where the moisture loss factor is defined as the cumulative weight percent moisture loss from an improved package, such as moisture retention package **200**, divided by the cumulative weight percent moisture loss from prior art package **100** (FIG. 1A)

## US 8,297,461 B2

11

for the same moistening solution, under the same conditions over the same time duration. As described above prior art package **100** comprises a standard prior art sidewall undercut surface **126** and a standard prior art skirt bead surface **128**, well known to those of ordinary skill in the art. As described, prior art sidewall undercut surface **126** cooperates with prior art skirt bead surface **128** to form prior art seal **106**.

As noted above, with reference to FIGS. **2A** and **2B**, in one embodiment, moisture retention closure **204** includes a top **214**, generally configured as a disk, and a skirt **216**, generally configured as an annular ring or skirt, coupled to and depending downwardly from top **214** at the peripheral edge of top **214**. Top **214** defines an aperture **218** (FIG. **2B**) therethrough for extracting material or objects contained in moisture retention canister **202** from opened-end portion **212** (FIG. **2B**). Moisture retention package **200** further includes an aperture lid **220** (FIG. **2A**) to close off aperture **218**. Aperture lid **220** may be coupled to moisture retention closure **204** by a living hinge **222**, by which aperture lid **220** pivots with respect to moisture retention closure **204** to close off aperture **218** (FIG. **2B**) of moisture retention closure **204**.

FIG. **3A** is a partial, close-up, top view of the moisture retention closure of FIG. **2A** showing moisture retention closure ring stand-offs **242** that provide venting to moisture retention package **200** (FIG. **2B**). FIG. **3B** is a close-up, partial, cross-sectional side view of the moisture retention closure **204** as in FIG. **2B** along line **3B-3B** of FIG. **3A** also showing an aperture lid **220** in a closed relationship with moisture retention closure **204**. Referring to FIGS. **3A** and **3B** together, in one embodiment, moisture retention package **200** (FIG. **2A**) may have a venting system. Providing a venting system to moisture retention package **200** allows release of excessive pressure buildup within moisture retention package **200** during elevated temperature testing or under excessive storage temperatures.

In one embodiment, moisture retention closure **204** includes a moisture retention closure sealing ring **234** projecting upwardly from top **214** of moisture retention closure **204**, similar to closure sealing ring **134** of prior art closure **104** shown in cross-section in FIG. **1B**. Aperture lid **220** includes a lid sealing ring **232** (FIG. **3B**) near the outer peripheral edge on the bottom surface of lid **220**, similar to lid sealing ring **132** of prior art closure **104** (FIG. **1B**). To form a seal between aperture lid **220** (FIG. **3B**) and moisture retention closure **204**, aperture lid **220** is snap-fitted to moisture retention closure **204**. Lid sealing ring **232** mates with a moisture retention closure sealing ring **234** formed on top **214** of moisture retention closure **204** when aperture lid **220** is pivoted, snap-fitted, and placed in a closed relationship with moisture retention closure **204** to form a seal as shown in FIG. **3B**. More specifically, a lid ring inside surface **238** of lid sealing ring **232** abuttingly contacts and seats against a closure ring outside surface **240** of moisture retention closure sealing ring **234**.

In this embodiment, to provide a venting system to moisture retention package **200** (FIG. **2A**), moisture retention closure sealing ring **234** further includes a pair of spaced apart stand-offs **242** configured as projections that extend radially outward from closure ring outside surface **240**. Stand-offs **242** define a vent gap **244** through which excessive pressure within moisture retention package **200** may be vented. Excessive pressure within moisture retention package occurs whenever the pressure within moisture retention package **200** is more than the pressure needed to overcome the snap-fit force between aperture lid **220** and moisture retention closure **204**. Said another way, excessive pressure within moisture retention package occurs whenever the pressure within moisture

12

retention package **200** would cause aperture lid **220** to overcome its snap-fitting force and “pop” off moisture retention closure **204**. In one embodiment, stand-offs **242** project about 0.0025 inches from closure ring outside surface **240** and stand-offs **242** are spaced apart by about 0.015 inches. In other embodiments, stand-off **242** may, alternatively, project radially inwardly from lid sealing ring **232**.

From this disclosure, one of ordinary skill in the art would recognize that other conventional materials and fabrication techniques could be substituted. Also based on this disclosure, the person of ordinary skill in the art would further recognize that the relative proportions of the components illustrated could be varied without departing from the spirit and scope of the invention.

Although the moisture retention package **200** employing an embodiment of the moisture retention seal **206** of the present invention shown in the drawings and described herein as substantially cylindrical, in fact, other structures having surfaces shaped other than cylindrical could employ the moisture retention seal **206** described and shown to achieve improved moisture retention over conventional prior art seals. Corresponding first and second component surface portions need only be of any suitable shape or cross-section to provide a sealing interface therebetween. The substantially cylindrical shape shown herein is believed to be advantageous because it may be efficiently and inexpensively manufactured using commonly available molding techniques.

Although the above discussion discloses various exemplary embodiments of the invention, it should be apparent that those skilled in the art can make various modifications that will achieve some of the advantages of the invention without departing from the true scope of the invention.

What is claimed is:

1. A package comprising:

a closure having an interior surface and a protrusion extending from the interior surface, the protrusion having a leading surface; and

a molded canister having a flexible top portion, the leading surface of the protrusion contacting the flexible top portion of the canister, the leading surface of the protrusion normally applying a generally downward contact force to at least part of the flexible top portion to form a top seal between the closure and the canister, the leading surface of the protrusion deflecting the part of the flexible top portion generally downwardly from a rest position,

wherein the flexible top portion of the canister is in the rest position when not connected with the closure, the leading edge of the protrusion deflecting the flexible top portion by a deflection angle from the rest position, the deflection angle being less than about ninety degrees when connected.

2. The package as defined by claim **1** wherein the leading surface of the protrusion is in abutting contact with the flexible top portion of the canister.

3. The package as defined by claim **1** wherein the canister is blow molded.

4. The package as defined by claim **1** wherein the protrusion comprises a solid member.

5. The package as defined by claim **1** wherein the protrusion abuts the flexible top portion of the canister.

6. The package as defined by claim **1** wherein the flexible top portion of the canister forms an opening, the protrusion abutting the flexible top portion to seal the opening about its entire circumference.



US 8,297,461 B2

13

7. The package as defined by claim 1 further comprising moistened wipes stored within the canister, the closure sealing the canister and closing the wipes from the exterior environment.

8. The package as defined by claim 1 further comprising a vent for venting the interior of the canister when the closure is coupled with the canister.

9. The package as defined by claim 1 further comprising a lid integrally coupled with the closure with a living hinge, the lid having an interior surface that is removably snap fit connectable with the closure to form another seal to seal the interior of the closure.

10. The package as defined by claim 1 wherein the closure forms an aperture for extracting objects from the canister, the closure further comprising a lid configured to alternatively form a closed relationship and an open relationship with the aperture in the closure, the lid sealing the closure and the canister when in a closed relationship with the closure and the closure and canister are coupled together.

11. The package as defined by claim 1 further comprising an additional seal between the closure and the canister.

12. A package comprising:

a closure having a non-planar interior surface having upper and lower portions and forming an aperture, the closure further comprising a lid configured to alternatively couple with the aperture in either one of a closed relationship and an open relationship, the lid being movable relative to the upper and lower portions of the closure; and

a canister having a bottom and a flexible top portion forming an opening covered by the closure, the upper portion of the closure being spaced a first distance from the bottom of the canister, the lower portion being spaced a second distance from the bottom of the canister, the first distance being greater than the second distance,

14

the lower portion of the interior surface forming a protrusion having a leading edge, the protrusion leading edge abutting the flexible top portion of the canister to normally apply a generally downward contact force to at least part of the flexible top portion to form a top seal between the closure and the canister, the leading edge of the lower portion deflecting the part of the flexible top portion generally downwardly from a rest position, wherein the flexible top portion of the canister is in the rest position when not connected with the closure, the lower portion of the interior surface deflecting the flexible top portion by a deflection angle from the rest position, the deflection angle being less than about ninety degrees when connected,

the lower portion abutting but not locking against the flexible top portion of the canister.

13. The package as defined by claim 12 wherein the closure includes a locking skirt, the canister having complimentary locking features, the locking skirt locking the complimentary locking features to secure the closure to the canister.

14. The package as defined by claim 12 wherein the lower portion has abutting contact only with the flexible top portion.

15. The package as defined by claim 12 wherein the lid has a substantially flat outer surface, the lid causing the closure to have a substantially planar upper surface when in the closed relationship.

16. The package as defined by claim 12 wherein the closure forms a rim and an integral living hinge extending therefrom, the living hinge being integrally coupled with the lid.

17. The package as defined by claim 12 further comprising moistened wipes stored within the canister, the closure sealing the canister and closing the wipes from the exterior environment, the package further comprising a vent for venting the interior of the canister when the closure is coupled with the canister.

\* \* \* \* \*

UNITED STATES PATENT AND TRADEMARK OFFICE  
**CERTIFICATE OF CORRECTION**

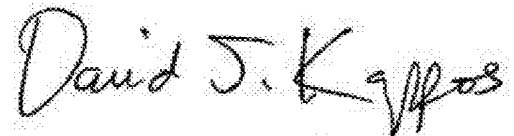
PATENT NO. : 8,297,461 B2  
APPLICATION NO. : 13/031634  
DATED : October 30, 2012  
INVENTOR(S) : Evans et al.

Page 1 of 1

It is certified that error appears in the above-identified patent and that said Letters Patent is hereby corrected as shown below:

In Col. 13, line 34, replace “begin” with “being”

Signed and Sealed this  
First Day of January, 2013

A handwritten signature in black ink that reads "David J. Kappos". The signature is written in a cursive, slightly slanted style.

David J. Kappos  
*Director of the United States Patent and Trademark Office*